

# Art. NTS48C MINI LARGE

FLOOR CLOSER SERIES MINI LARGE BOX CASE 95mm



**1 MILLION CYCLES TESTED**

PATENTED AND TESTED  
IN ACCORDING TO THE EUROPEAN STANDARD  
UNI-EN 1154:2003



THERMOSTATIC OIL -18°C +50°C  
TESTED TO ENSURE  
STABLE CLOSING TIMES  
TO THE DIFFERENT TEMPERATURE

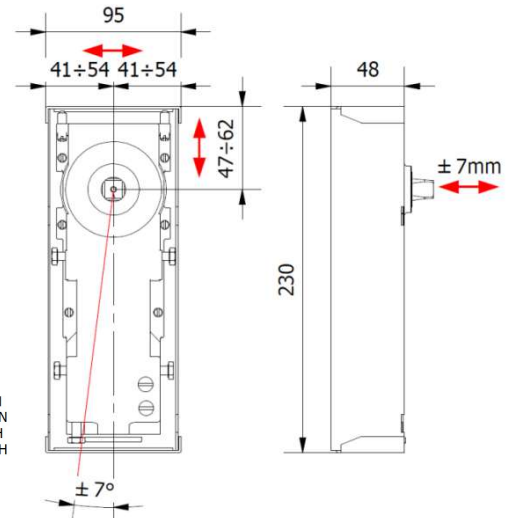
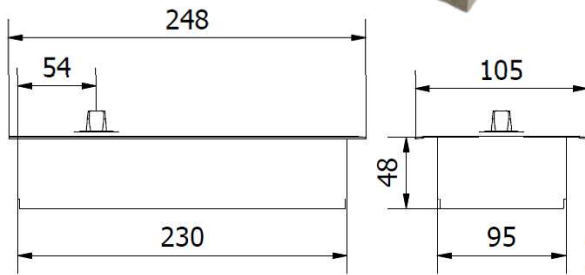

**10550X XX**

**HOLD OPEN**  
0= 90°  
1= 105°  
2= NO STOP

**FORCE**  
L= F2  
F= F3  
P= F3 PLUS

**SPINDLE**  
IT= ITALIAN  
RS= GERMAN  
FR= FRENCH  
SP= SPANISH

**SPINDLES:**

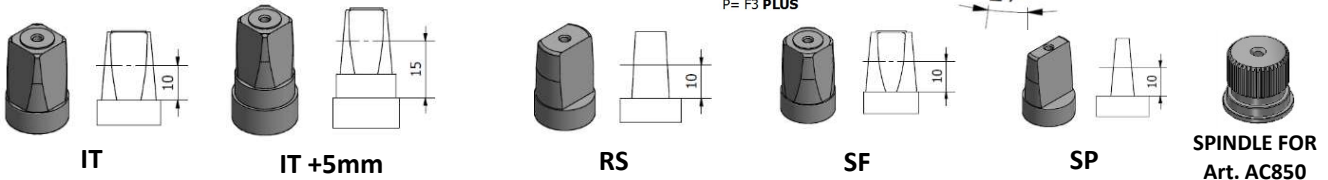

**NTS48C**

SERIES	ARTICLES	FORCE	HOLD OPEN	WEIGHT [KG]	WIDTH UP TO [MM]
NTS48C	10550L	F2	90°	80	500-800
	10551L	F2	110°	80	500-800
	10552L	F2	NO STOP	80	500-800
	10550F	F3	90°	120	700-1000
	10551F	F3	110°	120	700-1000
	10552F	F3	NO STOP	120	700-1000
	10550P	F3 PLUS	90°	120	950-1150
	10551P	F3 PLUS	110°	120	950-1150
	10552P	F3 PLUS	NO STOP	120	950-1150
	ARTICLE	DESCRIPTION		FINISH	CODE
		COVER		STAINLESS STEEL	INOX
				POLISHED BRASS	OT.LUX
		BOX CASE		STEEL PAINTED	STANDARD
				STAINLESS STEEL 304	BOX CASE STAINLESS STEEL

\* THE STANDARD PACKAGE INCLUDES THE STANDARD BOX CASE AND STAINLESS STEEL COVER AISI 304